

FS6 FORCE/TORQUE SENSOR

APPLICATIONS

The FS6 sensor is particularly suitable for applications requiring simultaneous measurement of several forces and moments, or measurements of forces that change direction and position over time. Common applications for this transducer include research and development in bone lengthening, machining, robotics, ergonomics, production processes, biomechanics, and dynamics.

DESCRIPTION

AMTI's FS6 fixator sensor is specifically designed for the precise measurement of forces and moments. The sensor measures the three orthogonal force components along the X, Y, and Z axes, and the moments about the axes, producing a total of six outputs. The characteristics of this strain gage sensor make it ideal for research and testing environments; it has high stiffness, high sensitivity, low cross-talk, excellent repeatability and long term stability. It is simple, easy to use, and is available in either 100, 250, or 500 pound (445, 1112, 2225 Newton) vertical capacities.

The body of the load cell is manufactured from a high strength aluminum alloy with a durable anodized finish. The instrument has mounting surfaces equipped with threaded holes.

CALIBRATION

Each sensor is inspected and tested in AMTI's calibration facility. The calibration procedure provides a detailed sensitivity matrix and a complete test of all system components, including the amplifier and the connecting cable if ordered together.

AMPLIFICATION

The FS6 Fixator Force/Torque Sensor incorporates strain gages mounted on a precision strain element to measure forces and moments. As with all conventional strain gage transducers, bridge excitation and signal amplification are required. AMTI's SGA or MCA amplifiers are high gain devices which provide excitation and amplification for multiple channels in one convenient package. The rack mountable MCA-6, or the desktop SGA6-4 provide the six channels of amplification required by the sensor. These amplifiers process the sensor's low-level signals and provide outputs suitable for an A/D converter so that the data can be stored and processed by a computer.



CUSTOM

AMTI also offers other transducers to meet your specific needs. Units with larger surface areas are available, and sensors with capacities as high as 3,000,000 pounds (13,345,000 Newtons) have also been constructed. Units are available in waterproof versions and in various sizes, load capacities, sensitivities, and materials.

FS6 FORCE/TORQUE SENSOR

FS6 SERIES SPECIFICATIONS	100	250	500
Fx, Fy Capacity, lb, (N)	50 (220)	125 (550)	250 (1100)
Fz Capacity, lb, (N)	100 (440)	250 (1100)	500 (2200)
Mx, My Capacity, in*lb, (Nm)	100 (11)	250 (28)	500 (56)
Mz Capacity, in*lb, (Nm)	50 (6)	125 (14)	250 (28)
Fx, Fy Sensitivity, $\mu\text{V}/[\text{V}*\text{lb}]$, ($\mu\text{V}/[\text{V}*\text{N}]$)	24 (5.4)	12 (2.7)	6.0 (1.35)
Fz Sensitivity, $\mu\text{V}/[\text{V}*\text{lb}]$, ($\mu\text{V}/[\text{V}*\text{N}]$)	6.0 (1.35)	3.0 (0.67)	1.5 (0.34)
Mx, My Sensitivity, $\mu\text{V}/[\text{V}*\text{in}*\text{lb}]$, ($\mu\text{V}/[\text{V}*\text{Nm}]$)	30 (265)	15 (132)	7.5 (66)
Mz Sensitivity, $\mu\text{V}/[\text{V}*\text{in}*\text{lb}]$, ($\mu\text{V}/[\text{V}*\text{Nm}]$)	24 (212.4)	12 (97.4)	6.0 (50.4)
Fx, Fy Stiffness, $\text{X}10^5 \text{ lb/in}$, ($\text{X}10^7 \text{ N/m}$)	0.12 (0.2)	.3 (0.5)	.6 (1.0)
Fz Stiffness, $\text{X}10^5 \text{ lb/in}$, ($\text{X}10^7 \text{ N/m}$)	1.7 (3)	4.5 (8)	9.0 (16)
Mz Stiffness, $\text{X}10^4 \text{ in}*\text{lb/radian}$, ($\text{X}10^4 \text{ Nm/radian}$)	2.0 (0.2)	5.0 (0.5)	10 (1.1)

FS6 DIMENSIONS

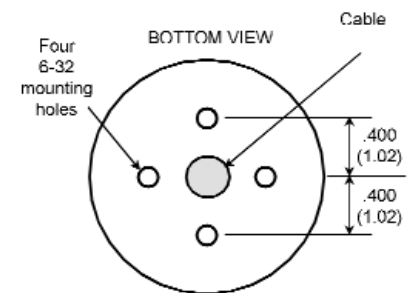
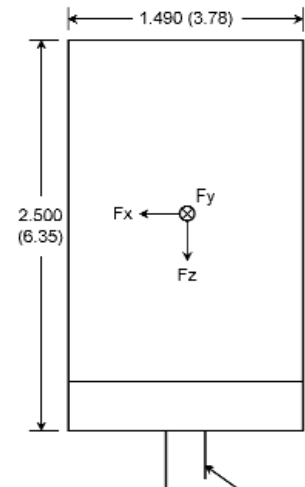
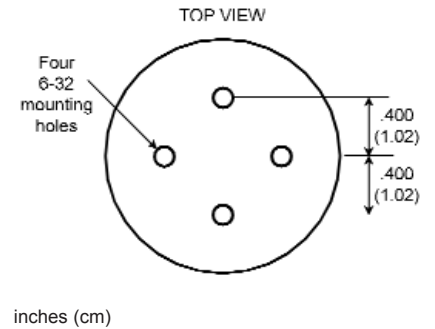

WIRING FOR FS6

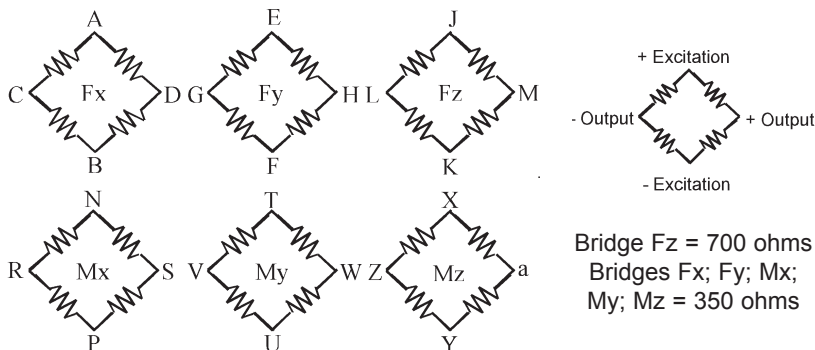

GENERAL SPECIFICATIONS

Weight: .22 lb (100 g)

Recommended Excitation: 10V or less

Crosstalk: Less than 2% on all channels

Temperature Range: 0 to 125°F, (-17 to 52°C)

Fx, Fy, Fz hysteresis: $\pm 0.2\%$ Full Scale Output

Fx, Fy, Fz non-linearity: $\pm 0.2\%$ Full Scale Output

ISO 9001 CERTIFIED

AMTI

ADVANCED MECHANICAL TECHNOLOGY, INC.
176 WALTHAM STREET WATERTOWN, MA 02472-4800
TEL: (617) 926-6700 • (800) 422-AMTI • FAX: (617) 926-5045
email: sales@amtmail.com • web: www.amtiweb.com