

UDW3 UNDERWATER SENSOR

APPLICATIONS

The UDW3 force/torque sensor is particularly suitable for underwater applications requiring simultaneous measurement of several forces and moments, or measurements of forces that change direction and position over time. Common applications for this transducer include research and development in tow tanks, underwater structure models, robotics, and ocean engineering.

DESCRIPTION

AMTI's UDW3 is specifically designed for the precise measurement of underwater forces and moments. The sensor measures the three orthogonal force and moment components along the X, Y, and Z axes, producing a total of six outputs. The characteristics of this strain gage sensor make it ideal for research and testing environments; it has high stiffness, high sensitivity, low cross-talk, excellent repeatability and long term stability. It is simple, easy to use, and is available with either 100, 250, 500, 1000 pound (445, 1112, 2225, 4450 Newton) vertical capacities.

The body of the load cell is manufactured from heat treated 17-4 PH stainless steel. The mounting surfaces are equipped with threaded holes, and the unit is sealed and filled with mineral oil. A pressure compensation bladder is used to equalize the internal and external pressures. This allows operation underwater with little effect on the force and moment outputs due to water pressure.

CALIBRATION

Each sensor is tested and calibrated in AMTI's facility. The calibration procedure provides a multi-point calibration of each channel and a complete test of all system components.

AMPLIFICATION

The UDW3 Underwater Force/Torque Sensor incorporates strain gages mounted on a precision strain element design to measure forces and moments. As with most conventional strain gage transducers, bridge excitation and signal amplification are required. The UDW3 can be used with any strain gage amplifier, including AMTI's product line.

AMTI's amplifiers are all high gain devices which provide excitation and amplification for multiple channels in one convenient package to suit different applications.



CUSTOM

AMTI also offers other transducers to meet your specific needs. Units with diameters as small as 1 inch (2.25 cm) are available, and sensors with capacities as high as 3,000,000 pounds (13,345,000 Newtons) have also been constructed. Units are available in various sizes, load capacities, sensitivities, and materials.

UDW3 UNDERWATER SENSOR

dimensions are inches (cm)

UDW3 SERIES SPECIFICATIONS	100	250	500	1000
Fx, Fy Capacity, lb, (N)	50 (222.4)	125 (556)	250 (1112.1)	500 (2224.1)
Fz Capacity, lb, (N)	100 (444.8)	250 (1112.1)	500 (2224.1)	1000 (4448.2)
Mx, My Capacity, in*lb, (Nm)	100 (11.3)	250 (28.2)	500 (56.5)	1000 (113)
Mz Capacity, in*lb, (Nm)	50 (5.6)	125 (14.1)	250 (28.2)	500 (56.5)
Fx, Fy Sensitivity, $\mu\text{V}/[\text{V}^*\text{lb}]$, ($\mu\text{V}/[\text{V}^*\text{N}]$)	24 (5.4)	12 (2.7)	6.0 (1.35)	3.0 (0.67)
Fz Sensitivity, $\mu\text{V}/[\text{V}^*\text{lb}]$, ($\mu\text{V}/[\text{V}^*\text{N}]$)	6.0 (1.35)	3.0 (0.67)	1.5 (0.34)	0.75 (0.17)
Mx, My Sensitivity, $\mu\text{V}/[\text{V}^*\text{in}^*\text{lb}]$, ($\mu\text{V}/[\text{V}^*\text{Nm}]$)	30 (265.5)	15.5 (137.2)	8.0 (70.8)	4.0 (35.4)
Mz Sensitivity, $\mu\text{V}/[\text{V}^*\text{in}^*\text{lb}]$, ($\mu\text{V}/[\text{V}^*\text{Nm}]$)	24 (212.4)	11 (97.4)	5.7 (50.4)	3.0 (26.6)
Fx, Fy Stiffness, $\text{X}10^5 \text{ lb/in}$, ($\text{X}10^7 \text{ N/m}$)	0.12 (0.21)	2.5 (0.53)	5.0 (1.06)	10 (2.12)
Fz Stiffness, $\text{X}10^5 \text{ lb/in}$, ($\text{X}10^7 \text{ N/m}$)	1.7 (2.98)	4.5 (7.88)	9.0 (15.76)	18 (31.54)
Mz Stiffness, $\text{X}10^4 \text{ in}^*\text{lb/radian}$, ($\text{X}10^4 \text{ Nm/radian}$)	2.0 (0.23)	5.0 (0.57)	10 (1.13)	20 (2.26)

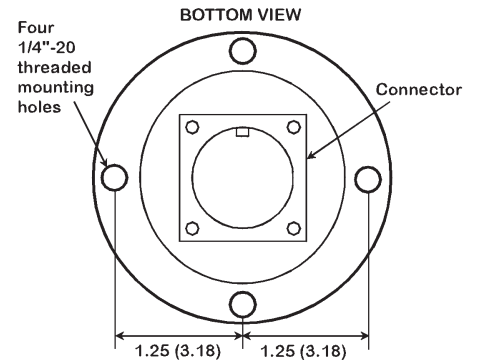
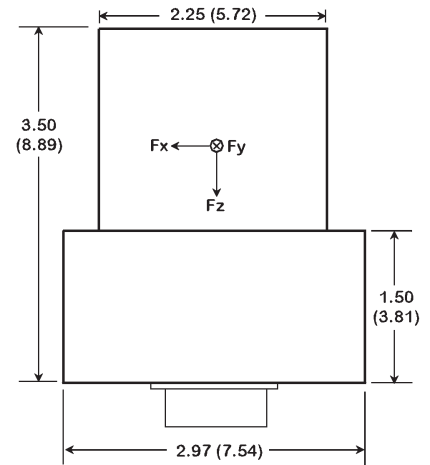
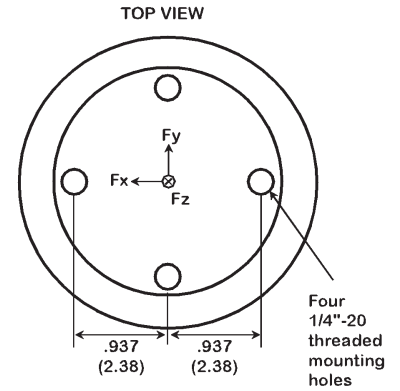

WIRING FOR UDW3 FORCE/TORQUE SENSOR

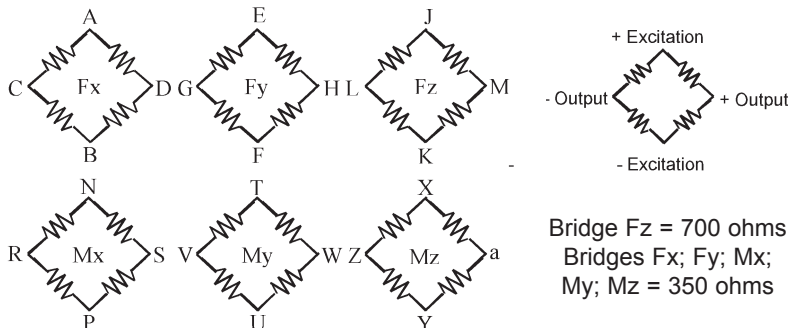

CONNECTOR TYPE:
Souriau 851-02E16-26P50-44

GENERAL SPECIFICATIONS

Weight: 4.5 lb (2 kg)
Recommended Excitation: 10V or less
Crosstalk: Less than 2% on all channels
Temperature Range: 0 to 125°F, (-17 to 52°C)
Fx, Fy, Fz hysteresis: $\pm 0.2\%$ Full Scale Output
Fx, Fy, Fz non-linearity: $\pm 0.2\%$ Full Scale Output

ISO 9001 CERTIFIED
AMTI
ADVANCED MECHANICAL TECHNOLOGY, INC.
 176 WALTHAM STREET WATERTOWN, MA 02472-4800
 TEL: (617) 926-6700 • (800) 422-AMTI • FAX: (617) 926-5045
 email: sales@amtmail.com • web: www.amtiweb.com